

Numerical Simulation for Design of Probe to Measure Hydrogen Thermal Conductivity at High Pressure by the Transient Short-Wire Method

by

Peter .L .WOODFIELD^{*}, Shogo MOROE^{**}, Jun FUKAI^{***}

Motoo FUJII[†], Masamichi KOHNO[‡], Yasuyuki TAKATA^{†††} and Kan'ei SHINZATO[§]

(Received November 5, 2007)

Abstract

Hydrogen energy is expected to be a next generation clean energy. However there are still many issues that must be overcome before commercializing hydrogen energy. Clarifying the mechanism for the effects of hydrogen on all types of materials and understanding the characteristics of hydrogen at high temperature and high pressure are indispensable. This study focuses on the development of the measurement technique for the thermal conductivity of hydrogen in the high pressure and the high temperature region. Numerical simulations are performed to investigate the effect of wire diameter, length and vessel size in a short-wire thermal conductivity probe designed for the study of hydrogen gas in the range of pressures from 0.1 to 100 MPa and temperatures from 25 to 500 °C. The two-dimensional unsteady heat conduction equation is discretized using the finite volume method to calculate the thermal field. The influence of the natural convection was examined using an empirical equation from the literature. The size of the vessel, the wire diameter, and the wire length respectively were changed within the range of $R=2.5\sim 50\text{mm}$, $d=5\sim 50\mu\text{m}$, and $H=20\sim 160\text{mm}$.

Keywords: Hydrogen, Thermal conductivity measurement, Short-wire method

1. Introduction

Recently, the world has been concerned by issues of energy resourcing, including fossil fuel use, global warming, and sustainable energy generation. It is expected that hydrogen will play an increasingly important role as an energy carrier in the near future. Hydrogen energy is expected to

^{*} AIST, Research Center for Hydrogen Industrial Use and Storage (HYDROGENIUS)

^{**} Graduate Student, Department of Mechanical Engineering

^{***} Professor, Department of Chemical Engineering

[†] AIST, Research Center for Hydrogen Industrial Use and Storage (HYDROGENIUS)

[‡] Associate Professor, Department of Mechanical Engineering

^{†††} Professor, Department of Mechanical Engineering

[§] AIST, Research Center for Hydrogen Industrial Use and Storage (HYDROGENIUS)

be a next generation clean energy. It is necessary to research and develop the hydrogen infrastructures such as the fuel distribution, hydrogen production and hydrogen storage system. On a more intricate level, fuel cell systems and fuel-cell vehicles that run on hydrogen are also presently being developed at a rapid pace in anticipation of a future hydrogen society. For development of hydrogen technology and for setting standards concerning safety and the sale of hydrogen to the public, thermophysical properties of hydrogen such as thermal conductivity, viscosity, and the PVT relationship need to be known accurately.

Much of the earlier work with hydrogen properties was collected and evaluated for engineering purposes by NIST (formally National Bureau of Standards) of the United States in the 70s and early 80s¹⁾. For thermal conductivity of hydrogen, Roder and Diller^{2,3)} of NIST took a large proportion of the presently available measurements using the guarded plate method and transient hot-wire method. The temperatures and pressures where their data were collected are limited to the low-temperature region as can be seen in **Fig. 1**. In the high temperature and high pressure region where no actual experimental data is available extrapolation has been made based on either empirical or theoretical considerations, such as the Enskog theory, excess thermal conductivity and/or an assumed connection between conductivity and viscosity. Such extrapolations raise major concerns about the accuracy of some published tables of thermal conductivity data. Acquisition of the measured data with reliability in the high temperature and the high-pressure region is an extremely important issue that must be addressed.

The dashed line in **Fig. 1** shows the target range of thermal conductivity measurement for hydrogen by our group. In this research, the aims are to measure thermal conductivity with high reliability in the high temperature and the high-pressure region shown in **Fig. 1**, to make a correlation for hydrogen thermal conductivity as a function of temperature and pressure, and to make the research results available in the form of fundamental data on physical properties of hydrogen for the coming hydrogen society.

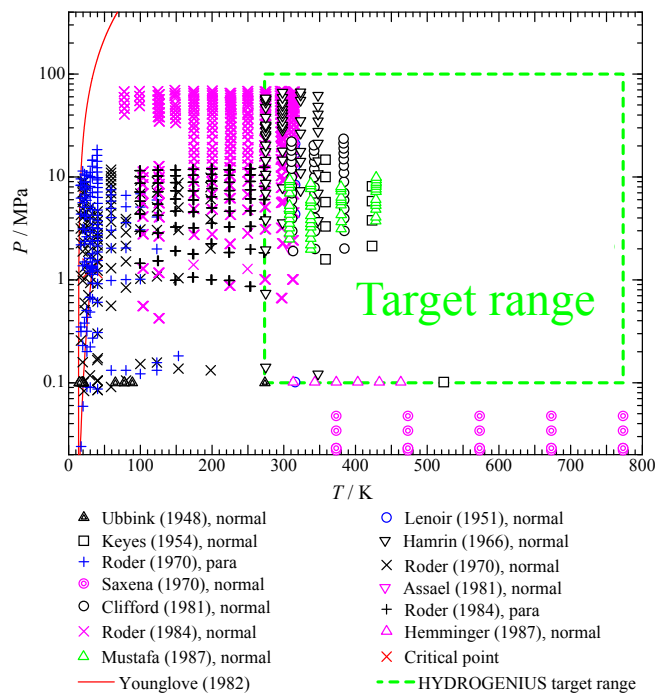

Fig. 1 Target range.

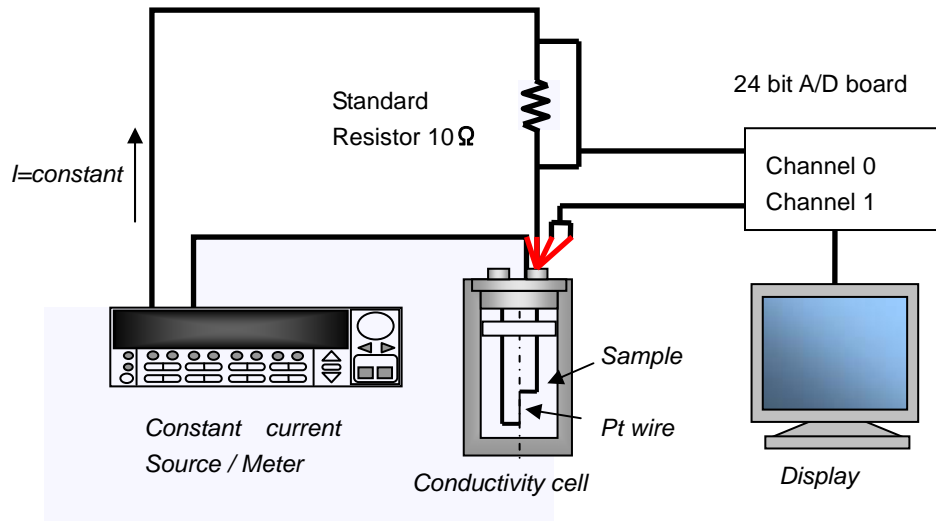

Fig. 2 Apparatus for transient short-wire method.

2. Short-Wire Method

The transient short-wire method for measuring thermal conductivity and thermal diffusivity was developed in the late 90s by Fujii et al.⁴⁻⁶ It is a variant of the conventional transient hot-wire method with the novelty that only one short conductivity cell is used and end-effects are accounted for by numerical simulation of unsteady heat conduction in the cell. The important potential application is the study of high pressure gas thermal conductivity⁷ where a small volume pressure vessel is highly desirable particularly from the point of view of ease of conformity with high pressure gas regulations.

The measurement principle of the transient short-wire method has been described in detail⁴. **Figure 2** shows a possible configuration of the apparatus for the present application. The sample fluid is placed in the conductivity cell which contains a short wire (usually platinum) having a diameter of the order of micrometers. Initially the temperature in the cell is uniform. The constant-current power source is switched on and the transient change in the voltage across the platinum wire is recorded. Simultaneously, the voltage across a standard resistor is recorded to accurately measure the electrical current flowing through the probe. Usually voltages are measured with digital multi-meters but alternatively they could be measured using an analog/digital conversion board inserted in a personal computer as shown in **Fig. 2**. Via calibration, the transient measured voltage can be converted to a volume-averaged transient temperature rise of the short wire. For a short-wire with known thermophysical properties, the non-dimensional volume-averaged hot-wire temperature θ_v depends highly on the thermophysical properties of the tested sample. For most liquids and high density gases, the wire temperature-rise increases linearly with the logarithm of time. λ and α are determined by correlating the slope and the intercept of the experimental line and of the calculated line.

The transient short-wire method has been successfully used to measure the thermal conductivity and thermal diffusivity of various fluids, molten polymer, and carbon nanofluids^{6,8,9}.

However, until now, it appears that the short-wire method has never been applied to hydrogen gas. This presents some challenges since hydrogen gas has properties that are quite different to the fluids for which the short-wire method has been tested and validated. The density of hydrogen is small compared with other gases and the thermal diffusivity α is about ten times larger than that of air. At atmospheric pressure, the thermal diffusivity of hydrogen is about 2000 times that of liquid toluene. The expected effect of these characteristics of hydrogen gas can be considered by numerical simulation and preliminary analysis, which is the aim of the present study. For example, the time to the onset of natural convection, effect of the test vessel size, wire length and wire diameter all can be investigated by simulation. Moreover, since the analysis procedure developed by Fujii et al.⁴⁻⁶⁾ depends on the temperature rise being a linear function of the logarithm of time, a curve-fitting procedure may need to be developed for conditions where the straight line requirement is not satisfied. The items that must be examined to measure the thermal conductivity of hydrogen successfully include the following.

- Effect of thermal diffusivity
- Effect of natural convection
- Effect of test vessel size
- Effect of wire length and diameter
- Curve fitting method

In this report we examine the effect of test vessel size, wire length and wire diameter.

3. Numerical Analysis

3.1 Analysis model

As much as possible, it is important that the theoretical model of the cell approximates the actual measurement cell closely. **Figure 3** shows the probe for thermal conductivity measurement. This probe is composed of the platinum wire and platinum terminals. The platinum wire of $10\mu\text{m}$ ϕ and platinum terminals of 1.5mm ϕ are bonded by spot welding. The geometry shown in **Fig. 3** probably requires a three-dimensional model for a complete treatment but it has been successfully approximated by an axis-symmetric two-dimensional model⁴⁾. In the present study, we apply a similar model to that used by Fujii et al.⁴⁻⁶⁾.

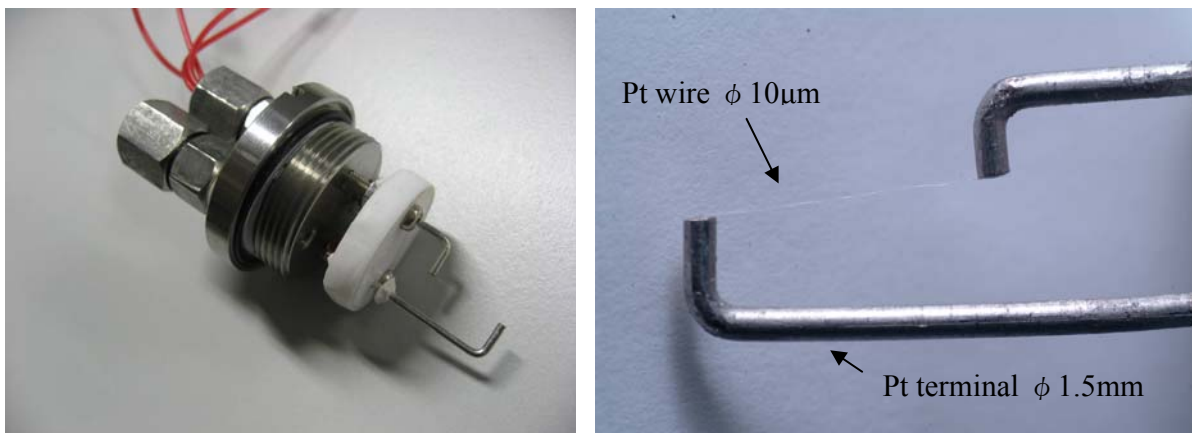

(a) entire shape.

(b) wire part shape.

Fig. 3 Probe for thermal conductivity measurement.

For a wire of radius, r_0 in a cylinder of radius R and height H with heat supplied at q per unit length, unsteady heat conduction is given by:

$$\rho c \frac{\partial T}{\partial t} = \frac{1}{r} \frac{\partial}{\partial r} \left(r \lambda \frac{\partial T}{\partial r} \right) + \frac{\partial}{\partial z} \left(\lambda \frac{\partial T}{\partial z} \right) + Q \quad (1)$$

$$Q = \begin{cases} q/\pi r_0^2 & (r \leq r_0) \\ 0 & (r > r_0) \end{cases} \quad (2)$$

$$T|_{r=R} = T_0 \quad (3)$$

$$T|_{z=0} = T_0 \quad (4)$$

$$T|_{z=H} = T_0 \quad (5)$$

$$T|_{t=0} = T_0 \quad (6)$$

$$\lambda|_{r \leq r_0} = \lambda_w \quad \lambda|_{r > r_0} = \lambda_s \quad (7a)$$

$$\rho c|_{r \leq r_0} = \rho_w c_w \quad \rho c|_{r > r_0} = \rho_s c_s \quad (7b)$$

where the subscript 'w' is for wire and 's' is for sample. Equation (2) gives the heat source to the short-wire which is assumed to be constant for all $t > 0$ at all positions in the wire. Isothermal boundary conditions are assumed on the walls of the cell (Eq. (3)) and at the top and the bottom of the wire where it connects to the terminals (Eqs. (4) and (5)). The initial condition of a uniform temperature is given by Eq. (6) and the difference in thermophysical properties between the wire and the sample are given by Eq. (7).

3.2 Numerical discretization

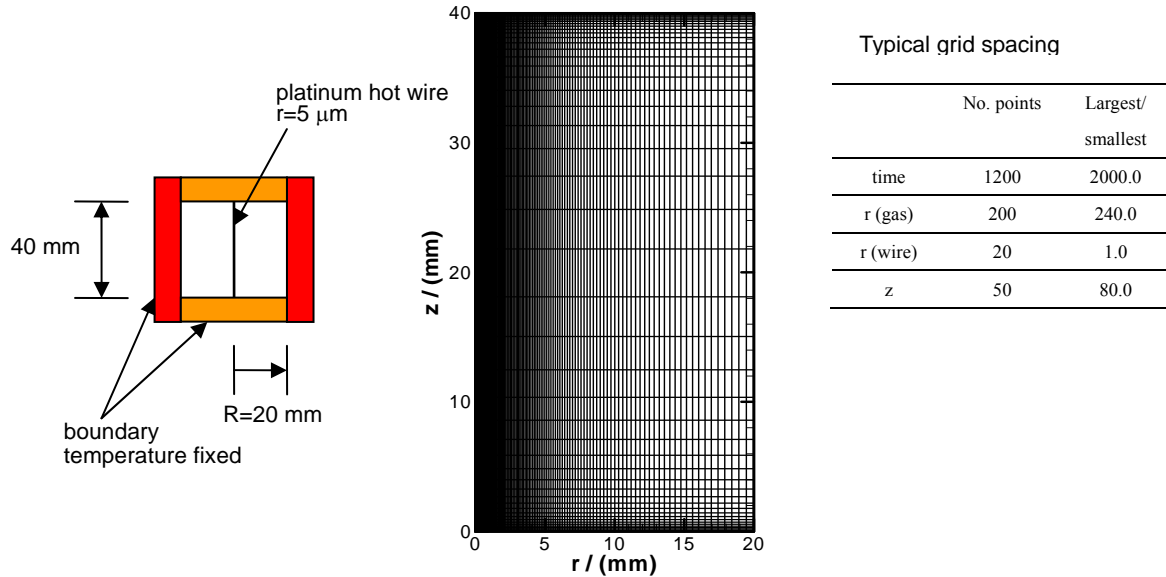

Fig. 4 Two-dimensional grid for short-wire calculation.

Equation (1) is discretized using the finite volume method¹⁰⁾ with central differencing for the conduction terms and a fully implicit formulation for the unsteady term. **Figure 4** shows the grid

and basic geometry considered. Typical grid spacings and time-step sizes for the simulation are also listed in **Fig. 4**. Because temperature gradients are very steep near the wire and temperatures change most rapidly at the start, it is more efficient to use non-uniform grid spacing and non-uniform time stepping. The ratios of the largest to the smallest grid and time-step sizes are also given in **Fig. 4**.

Grid sensitivity calculations were performed by doubling the number of grid points in each direction and also by doubling the number of time steps. **Figure 5** shows the grid convergence. The agreement between the fine grid (symbols) and the base grid (solid lines) is very good. The steady-state temperature distribution is also in good agreement for the two grid arrangements. Therefore for the present purposes it may be considered that the base grid is fine enough.

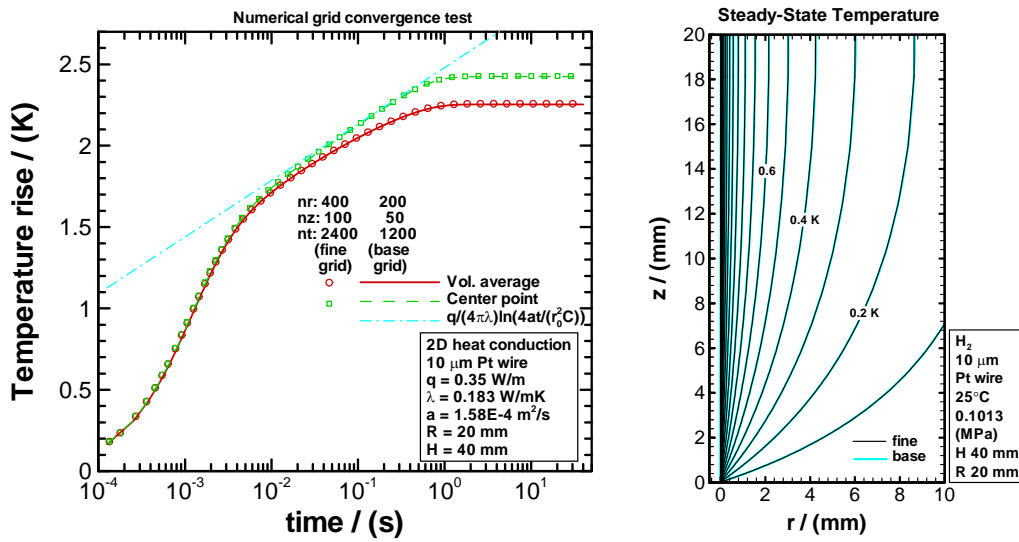

Fig. 5 Grid convergence test.

3.3 Natural convection considerations

Natural convection is an important issue for all measurements of fluid thermal conductivity. One of the strengths of the transient hot-wire method is that data can be collected before the onset of natural convection effects. Zhang et al.⁵⁾ give an empirical equation for estimating the Fourier number corresponding to the onset of natural convection. Eq. (8b) gives the dimensional form for the critical time.

$$Fo_c = 8.3(Ra_H^*)^{-2/3}(H/d)^3 \quad (8)$$

$$t_c = 8.3 \frac{r_0^2}{\alpha} \left(\frac{qH}{2\pi r_0 \Delta T \lambda} \frac{g\beta \Delta T H^3}{\nu \alpha} \right)^{-2/3} \left(\frac{H}{2r_0} \right)^3 \quad (8b)$$

They recommend Eq. (9) to obtain the maximum time for accurate measurements.

$$Fo_c = 2.9(Ra_H^*)^{-2/3}(H/d)^3 \quad (9)$$

Rather than attempt to solve the flow-field numerically, in the present article we make use of Equations (8) and (9) to give us a preliminary estimate of the time available for thermal

conductivity measurement prior to the onset of natural convection effects.

3.4 Results and discussions

Figure 6 shows the effect of the vessel radius when the height (i.e. length of the wire) is either 20 mm (**Fig. 6(a)**) or 40 mm (**Fig. 6(b)**). The red lines show volume averaged wire temperatures while the green dotted lines show the temperature of the wire center. The light blue line gives the equation used in the conventional hot-wire method¹¹⁾. The symbols show the times predicted by Eqs. (8) and (9) for the onset of natural convection. The assumed thermal conductivity and diffusivity correspond to hydrogen at atmospheric pressure and room temperature. For this condition thermal diffusivity is very large compared to other fluids. Ideally we want a straight curve between $t = 0.1$ s and $t = 1.0$ s. For all cases in **Fig. 6(a)** this is not achieved. Even for the taller vessel $H=40$ mm shown in **Fig. 6(b)** with $R=50$ mm the effect of the vessel wall appears to begin in less than 1.0 seconds. At very small values of time the curves are the same for all R since the wire behaves as though it is in a semi-infinite medium. As should be expected, the steady-state is reached more quickly if the radius of the vessel is smaller. Since R does not appear in Eq. (1), the times for the onset of natural convection are the same in **Fig. 6(a)** for all R .

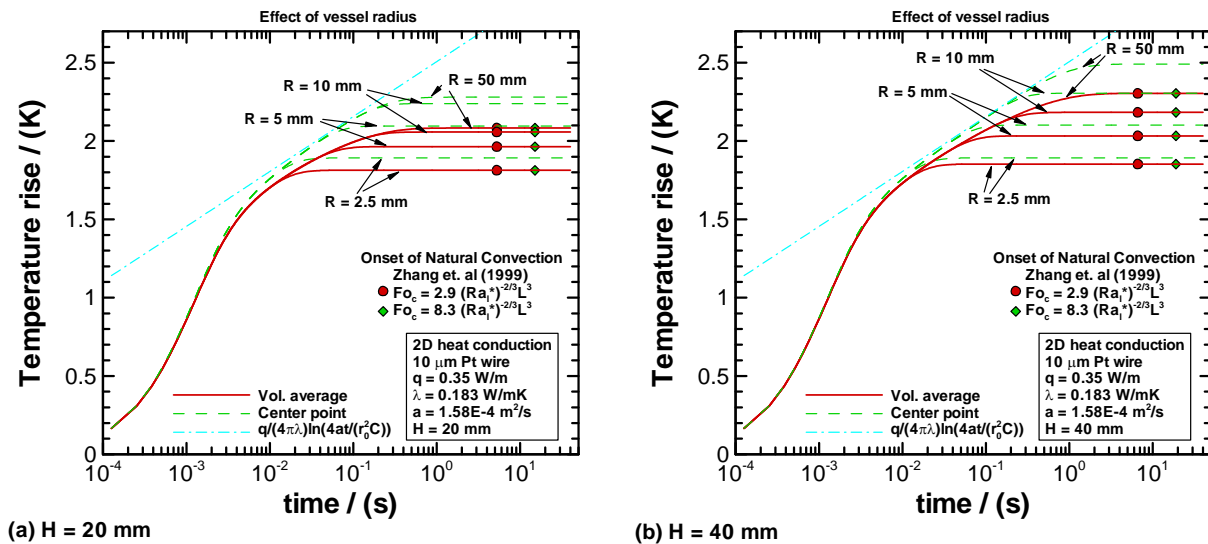

Fig. 6 Effect of vessel radius for two different wire lengths.

Figure 7 shows the effect of changing the wire diameter. The main influence of the wire diameter is felt at small values of time. Unlike **Fig. 6**, for all cases in **Fig. 7(a)**, the steady-state is reached at around the same time. The final steady-state temperature rise is smaller for a larger diameter wire as should be expected since for steady 1D heat conduction between concentric cylinders the temperature difference is proportional to $\ln(R/r)$ if the total heat exchange rate is fixed. For the present application to hydrogen, it appears that the 10 micrometer wire may be small enough since it may not be possible to accurately measure the curve for $t < 0.01$ seconds. For the period $0.1 < t < 1.0$ s, the larger sample vessel (**Fig. 7(b)**) is clearly better than the smaller vessel (**Fig. 7(a)**). Natural convection onset times become shorter as the wire diameter is increased but all cases the steady-state is reached prior to the predicted onset of natural convection. Moreover, all estimates of natural convection onset in **Fig. 7** appear at times greater than about 3 seconds. This suggests that natural convection may not be a major problem for hydrogen at atmospheric pressure.

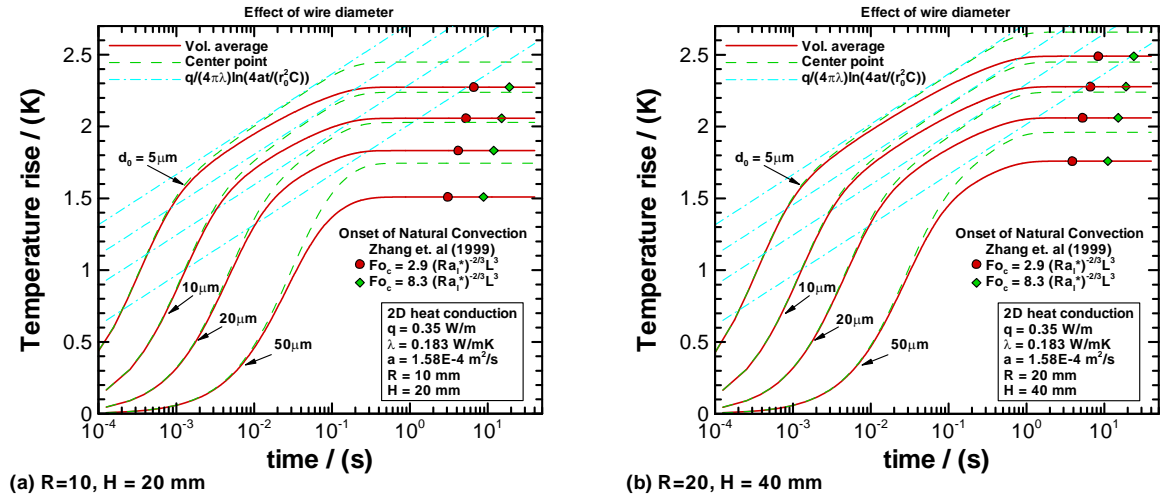

Fig. 7 Effect of wire diameter for two different cell sizes.

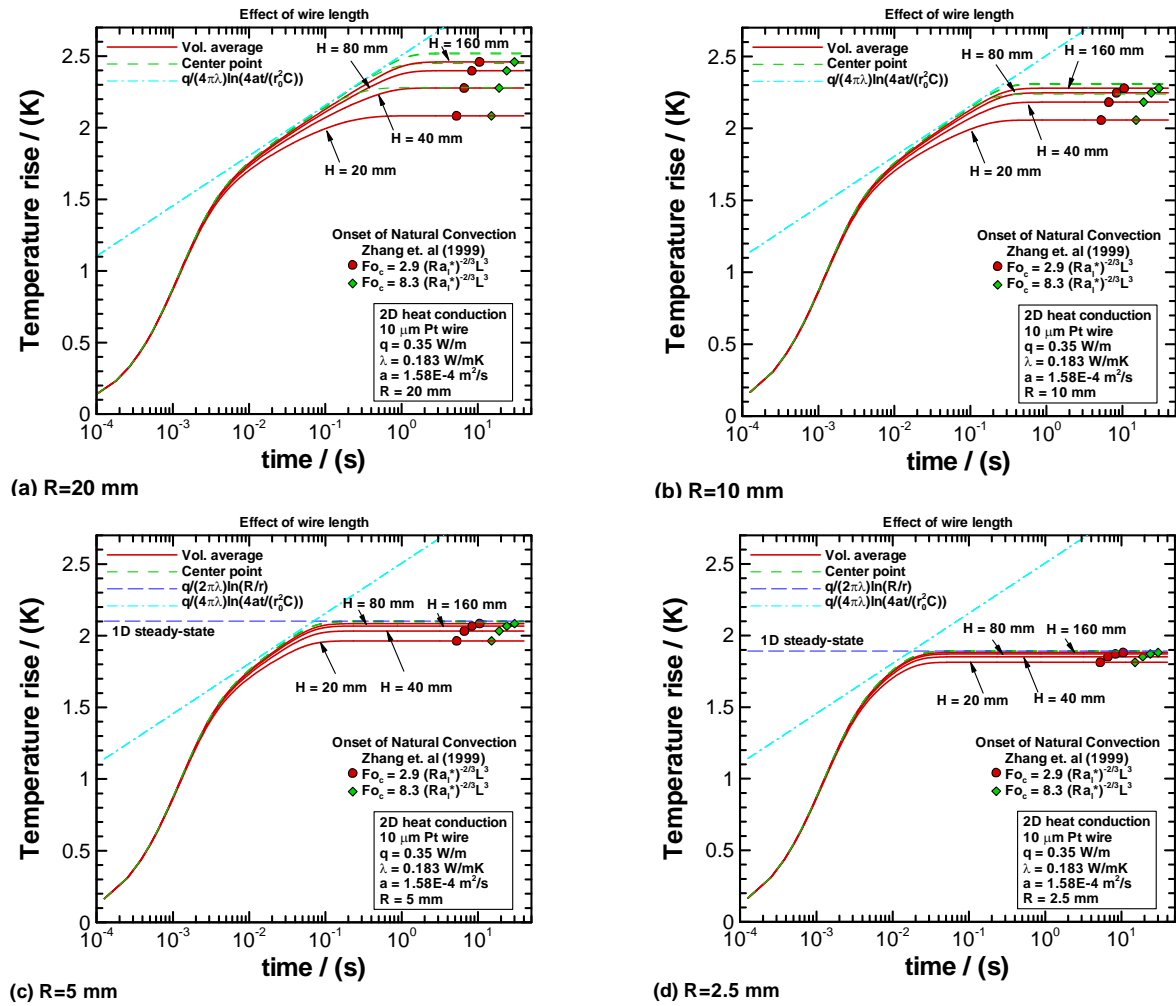

Fig. 8 Effect of wire length for four different cell radii.

Figure 8 shows the effect of changing the wire length for four different vessel diameters. Generally, as the length of the wire is increased the center point temperature and the volume averaged wire temperature become closer together. In the limit of a very long wire for large time the volume averaged wire temperature approaches the analytical one-dimensional steady-state conduction solution. This is shown by the dark dashed line in **Figs. 8(c)** and **8(d)**. Another interesting feature of **Fig. 8** is that for very short times the length of the wire is not critical. As in **Fig. 6**, this is related to the wire behaving as though it is in a semi-infinite container. Also, comparing **Fig. 8(b)** with **Fig. 8(d)** it is apparent that the importance of the length of the wire decreases if the radius of the vessel is smaller. In **Fig. 8(d)** the steady-state is reached very quickly suggesting that a steady-state method might be useful for measuring the thermal conductivity if the vessel diameter is small (<5 mm) and the length is greater than about 80 mm. For the transient method **Fig. 8** indicates that larger vessels are better. Finally from **Fig. 8**, natural convection is predicted to occur later if the wire is longer.

Figure 9 shows the effect of changing the heating rate for the wire. As may be expected the temperature rise is greater if heat is supplied to the wire more quickly. In fact, the temperature rise for any point in time increases in direct proportion with the power supplied to the wire. The natural convection onset time becomes shorter for a higher heating rate.

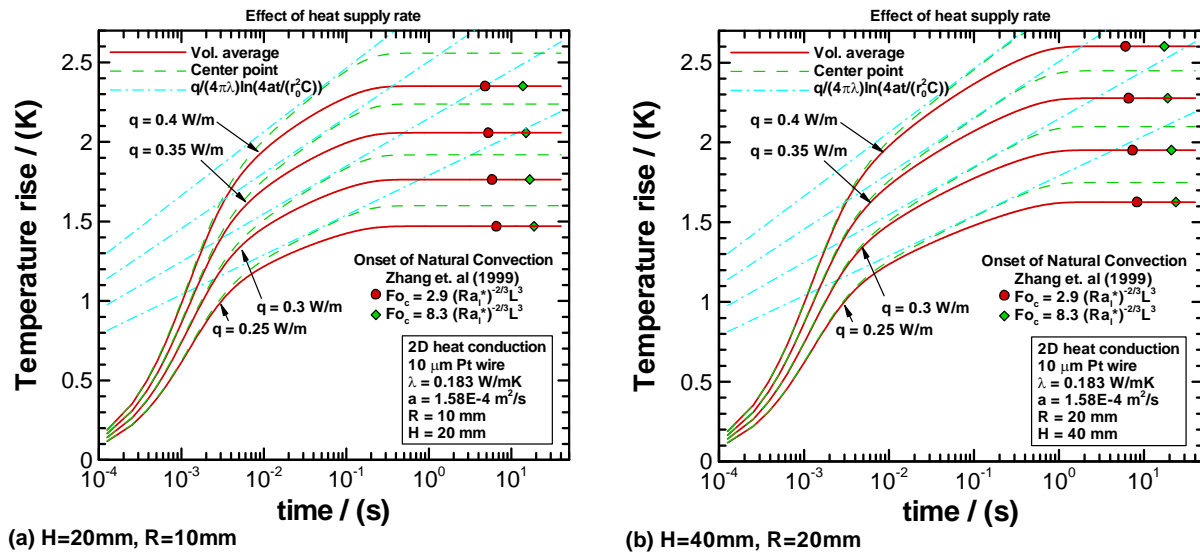

Fig. 9 Effect of heating rate for two different cell sizes.

All of the above figures were for hydrogen at atmospheric pressure. If the pressure is increased the density changes dramatically and likewise the thermal diffusivity becomes smaller. **Figure 10** shows the effect of hydrogen pressure. Properties were taken from the NIST web-book. As the pressure is increased the curve becomes straighter and the steady-state is delayed to much greater values of time. For a fixed value of q (power to the wire) with increasing pressure, the temperature rise is lower because both the heat capacity and the thermal diffusivity of hydrogen are larger. This is consistent with conventional hot-wire theory. The tendency for the curve to approach a straight line indicates that the transient short-wire method is expected to perform better in hydrogen at higher pressures. The onset of natural convection happens earlier as the pressure is raised from 0.1013 MPa to 10 MPa. However, all cases are still larger than 1.0 s. Thus we may conclude that

based on the empirical relation by Zhang et al⁵⁾, natural convection can be avoided by measuring only for time less than one second.

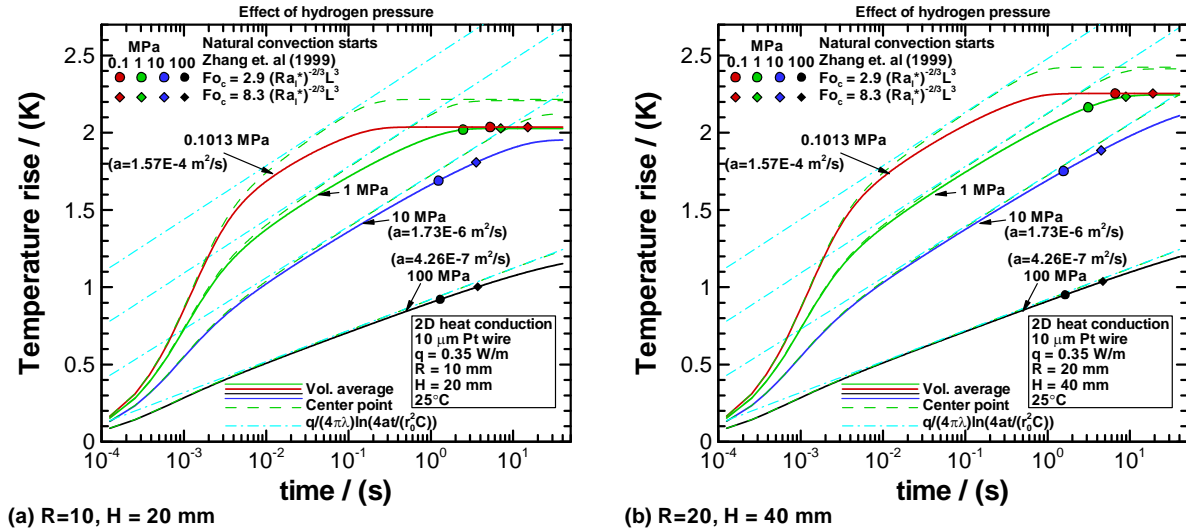

Fig. 10 Effect of hydrogen pressure.

4. Conclusions

The effects of the size of the vessel, the wire diameter, the wire length, heating rate and pressure of hydrogen were examined. The results are concluded as follows.

- The large thermal diffusivity of hydrogen at pressures lower than 10 MPa cause the radius and diameter of the cell to have a large influence on the predicted temperature rise of the wire.
- At pressures lower than about 10 MPa the temperature rise versus the logarithm of time is not a straight line. At atmospheric pressure a steady-state for almost all cases considered was reached in less than one second.
- A larger vessel is preferable for the transient short-wire method applied to hydrogen gas at low and moderate pressures. However, at high pressures a small vessel yields a straight line and is more suitable from a practical point of view.
- A 10 micrometer diameter wire may be small enough for the present purposes.
- Natural convection is predicted to occur later if the wire is longer.
- The natural convection onset time becomes shorter for a higher heating rate.
- A modified curve-fitting procedure will be necessary for application of the transient short-wire method to measurement of hydrogen thermal conductivity for the desired range of pressures.
- At pressures around atmospheric, a steady-state approach may be worth considering if the sample vessel size needs to be reduced.
- Natural convection might not be a serious problem if the equation developed by Zhang et al.⁵⁾ is applicable.
- It is necessary to consider the effects of the boundary conditions for the model (Eqs. (4) and (5)) in order to better approximate the real probe shape (Fig. 3) and the size of the vessel.

Acknowledgements

This research has been conducted as a part of the “Fundamental Research Project on Advanced Hydrogen Science” funded by New Energy and Industrial Technology Development Organization (NEDO).

Nomenclature

λ	thermal conductivity [W m ⁻¹ K ⁻¹]
α	thermal diffusivity [m ² s ⁻¹]
ρ	density [kg m ⁻³]
c	specific heat [J kg ⁻¹ K ⁻¹]
T	temperature [K]
t	time [s]
r_0	wire of radius [m]
R	cylinder of radius [m]
q	heat flux [Wm ⁻²]
Q	amount of heat[W]
Fo	Fourier number [-]
Ra	Rayleigh number [-]
H	height [m]
g	gravity acceleration [ms ⁻²]
ν	kinematic viscosity [m ² s ⁻¹]
β	volumetric coefficient of expansion [K ⁻¹]
d	wire diameter [m]

References

- 1) R. D. McCarty, J. Hord, H. M. Roder, Selected properties of hydrogen (engineering design data), National Bureau of Standards Monograph, (1981).
- 2) H. M. Roder, D. E. Diller, Thermal conductivity of gaseous and liquid hydrogen, J. Chemical Physics, Vol. 52, No.11, p.5928, (1970).
- 3) H. M. Roder, Thermal conductivity of hydrogen for temperatures between 78 and 310 K with pressures to 70 MPa, Int. J. Thermophys, Vol. 5, No.4, p.323, (1984).
- 4) M. Fujii, X. Zhang, N. Imaishi, S. Fujiwara and T. Sakamoto, Simultaneous measurements of thermal conductivity and thermal diffusivity of liquids under microgravity conditions, Int. J. Thermophys, Vol. 18, No.2, p.327, (1997).
- 5) X. Zhang, S. Fujiwara, Z. Qi, M. Fujii, Natural convection effect on transient short-hot-wire method, J. Jpn. Soc. Microgravity Appl. Vol. 16 No. 2 (1999) 129-135.
- 6) X. Zhang, W. Hendro, M. Fujii, T. Tomimura, N. Imaishi, Measurements of the thermal conductivity and thermal diffusivity of polymer melts with the short-hot-wire method, International Journal of Thermophysics, Vol. 23, No. 4, pp. 1077-1090, (2002).
- 7) N. Sakoda, E. Yusibani, P. L. Woodfield, K. Shinzato, M. Kohno, Y. Takata, M. Fujii, Review of the thermophysical properties of hydrogen and the related work of HYDROGENIUS, Proc.8th Asian Thermophysical Properties Conference, August 2007, Fukuoka, Japan
- 8) T. Tomimura, S. Maki, X. Zhang, M. Fujii, Measurements of thermal conductivity and thermal

diffusivity of alternative refrigerants in liquid phase with a transient short-hot-wire method, *Heat Transfer-Asian Research*, Vol.33, No. 8, p. 540, (2004).

- 9) H. Gu, H. Xie, M. Fujii and X. Zhang, Measurement of thermal and electrical properties of packed carbon nanofibers, Proc. of the 7th Asian Thermophysical properties Conference, China, August 23-28, 2004.
- 10) S. V. Patankar, Numerical Heat Transfer and Fluid Flow, Hemisphere Publishing Corporation 1980.
- 11) Y. Nagasaka, A. Nagashima, Simultaneous measurement of the thermal conductivity and the thermal diffusivity of liquids by the transient hot-wire method, Rev. Sci. Instrum. 52 (1981) 229-232.